

Encouraging Interest In Engineering Through Embedded System Design

M.L. Neilsen¹, D.H. Lenhart², M. Mizuno¹, G. Singh¹, J. Staver³,
N. Zhang⁴, K. Kramer³, W.J. Rust³, Q. Stoll⁴, and M.S. Uddin⁴

¹ Department of Computing and Information Sciences, College of Engineering,
Kansas State University (KSU), {neilsen,masaaki,singh}@cis.ksu.edu*

² Department of Electrical and Computer Engineering, KSU, lenhart@ksu.edu*

³ College of Education, KSU, {staver,kkramer,wjr}@ksu.edu*

⁴ Department of Biological and Agricultural Engineering, KSU, zhangn@ksu.edu*

Abstract

Rapid advances in embedded systems present significant opportunities for fundamental change in education, at all levels, with a greater focus on active, collaborative learning. These advances can be exploited by integrating them into the elementary and middle school curriculums and by having students work in teams to develop innovative new solutions to embedded design problems in science and engineering. Such hands-on activities provide concrete experiences for abstract lessons in math and science and motivate students to learn more complex abstract concepts.

A collaborative research experience for upper elementary and middle school teachers has been initiated at Kansas State University to enable teachers to become agents of change and engage their students in the engineering process at an early age – before high school. This is the time when many students begin formulating career directions, and we want them to consider computing sciences and engineering as viable career options. This paper describes the structure of our Research Experiences for Teachers (RET) Site in real-time embedded system design, and the lessons we have learned during its first year in operation.

1 Introduction

The number of embedded electronic systems used in automobiles, industrial automation, and other control systems continues to increase dramatically. These systems typically include subsystems with separate processors. The processors must communicate to coordinate their activities. A typical system consists of an interconnected collection of distributed processors

* This material is based upon work supported by the National Science Foundation under NSF Grant No. 0227709. Any opinions, findings, and conclusions or recommendations expressed in this material are those of the author(s) and do not necessarily reflect the views of the National Science Foundation.

connected by a real-time network. As these systems become even more complex, the need for real-time embedded systems research and students interested in embedded system development become even more critical.

Design and implementation of embedded systems requires a *broad knowledge* in areas traditionally not covered in any one discipline. These areas include electrical and computer engineering, computing sciences, mechanical engineering, and other engineering disciplines. As a result, it is very difficult to train students and engineers within a single discipline to effectively design and implement complex real-time embedded systems. Thus, we felt that it was important to first establish an *interdisciplinary framework* of structured courses for education in real-time embedded system design [2]. One of the major goals of this new curriculum is to expose students to industrial and commercial quality implementations and *bridge the gap between conceptual understanding and concrete implementations*. After undergraduate and graduate students are able to apply abstract knowledge in concrete implementations, subsequent higher-level, theory-oriented courses have more relevance.

The same problem exists in elementary and middle schools where students lack an understanding of the connection between abstract mathematics and concrete implementations, and teachers struggle to motivate students to appreciate the importance of learning abstract concepts. To provide an entry level that is attractive to both upper elementary and middle school teachers, our initial focus is on the Lego MindstormsTM Robotics Invention System, object-oriented programming, and simple embedded sensors and actuators. These designs naturally motivate both teachers and students to acquire a much deeper understanding of the underlying mathematics and science. In addition to working on simple embedded control systems that teachers take back to their own schools, they also work with graduate students and faculty members on research problems involving more complex real-time embedded systems. In this way, teachers gain a deeper understanding of embedded system design. They also have many new practical skills that can be put to use in the upper elementary and middle school classrooms immediately. This project involves the active participation of thirty elementary/middle school teachers (ten each year), from both rural and urban areas in Kansas, and provides participants with the tools and knowledge necessary to feel confident as resources for students and other teachers.

The next section provides some background information. Then, Section 3 describes the research experience through on-campus activities completed last summer and on-going activities in progress during the current academic year. Finally, the paper concludes in Section 4 with a summary and recommendations for future work.

2 Background

Traditional approaches to system design in computing sciences have focused primarily on software design, whereas system design in other engineering disciplines has focused primarily on hardware design. With the introduction of inexpensive microprocessors, it became possible to provide students with hands-on laboratory experiences to construct simple embedded systems. As these systems have evolved in commercial applications, the number and complexity of

embedded controllers has also increased. A significant portion of the design process must now focus on software engineering and the integration of hardware and software. However, most microprocessor-based system courses still emphasize hardware construction [4,5]. In order to address both software and hardware issues, it becomes essential to apply an *interdisciplinary approach*.

Many microcontrollers are used in real-time control systems such as automotive electronics and factory automation. To be practical for industry, the per-unit cost must be strictly controlled, but the development platform can be fairly expensive as long as the development cost can be amortized over thousands or millions of units. However, in an academic environment, the cost per development platform must be controlled to fit within a typically constrained laboratory budget. Early in the development process, this was a limitation in trying to establish a collection of inter-departmental laboratories. More recently, we have benefited by the foresight of many leading development platform vendors, both software and hardware. Development environments should support source-level debugging, simulators, profiling, and analysis tools. Many developers are now offering Educational Partner Programs to enable the integration of these sophisticated development tools into the curriculum.

Another frequently required technology is a real-time operating system (RTOS). We currently use both commercial (VxWorks) and open source (ERIKA, LeJOS, BrickOS, etc.) operating systems. We also built an RTOS that provides an efficient and extensible set of services. The functionality of the RTOS includes scheduling and thread context switching capability, synchronization primitives, and micro-interrupt handlers for interruptible peripheral devices. On top of the RTOS, various functions can be implemented as independent threads. All of these real-time operating systems can be used in either *simulation* or *execution* mode.

Applications of embedded systems in industrial and agricultural applications usually involve a large number of various types of *sensors* and *actuators* connected by a real-time network. The rapid increase of such applications requires in-depth research to correctly interface multiple sensors and actuators. These applications serve as excellent case studies to motivate students and teachers. Fast computation speed has been a major barrier for many real-time sensing and control applications, especially for sensors requesting a large amount of computation, such as image sensors. In on-going research, we are integrating Digital Signal Processors (DSP) into a real-time embedded system in order to accomplish the fast image processing required for real-time weed detection and spray control. DSPs designed for real-time digital signal and image processing greatly enhance the processing speed by adopting parallel architectures. Advanced DSPs, such as the TMS320C80 parallel processor, contain up to five fully programmable processors for high speed, parallel processing. Such a processor is very capable of processing images covering a sufficient width for a standard herbicide applicator, at a processing speed of 40-50 image frames per second. This allows a 4-5 mph ground velocity for the applicator [6]. In another on-going research project, we are developing a field-level Geographic Information System (GIS), which integrates multiple map layers, including remotely sensed imagery, with real-time positioning signals received from the Global Positioning System (GPS) [7]. Such a system can be used for many real-time field applications, including variable-rate chemical applications, variable seed-

rate planting, and yield mapping. For these applications, fast computation speed is always a central issue and is an excellent application of our research on hardware/software tradeoffs.



Figure 1. Redroot pigweed at different density levels.

For example, one capstone project focuses on agricultural applications involving variable-rate technology (VRT). Infrared sensors are used to collect information (Figure 1). Then, distributed controllers evaluate the input and generate variable-rate application recommendations in real-time. All sensors, controllers, and actuators are networked together using a real-time controller area network.



Figure 2. Weed detection system with variable rate applicator.

The importance of real-time networking becomes more obvious when applications involving multiple subsystems, each containing a large number of sensors and actuators, are developed. Modern agricultural machines are equipped with advanced, microprocessor-based embedded systems. For example, a modern tractor may use several electronic control units and hundreds of sensors and actuators to monitor and improve its performance. With the rapid development of new technologies for precision agriculture, more sensors and actuators with sophisticated control algorithms will be added to the system. This requires more complex and reliable networking

techniques. We are currently conducting research on real-time image and optical weed sensors, particle flow sensors [6], soil moisture sensors [8], and standing wave sensors. Numerous other sensors have been developed for precision agriculture. Many of these sensors may be linked with a real-time network to log sensory data and provide feedback for real-time control. A current trend in agriculture is to apply fertilizers and chemicals at variable rates to enhance efficiency and reduce environmental impacts. A typical variable rate technology (VRT) design requires both sensors and actuators on a real-time network as shown in Figure 2.

The next section describes our progress in making such advanced research concepts accessible to elementary and middle school teachers through a Research Experiences for Teachers (RET) Site at Kansas State University, funded in part by the National Science Foundation.

3. Research Experience for Teachers

The goal of this project is to provide thirty upper elementary and middle school teachers with a challenging experience in real-time embedded system design and an opportunity to acquire new practical skills that can be applied directly in their own classrooms.

3.1 Project Structure

The on-campus activities of the project are carried out during an intensive four-week summer session in which teachers attend two four-hour sessions each day.

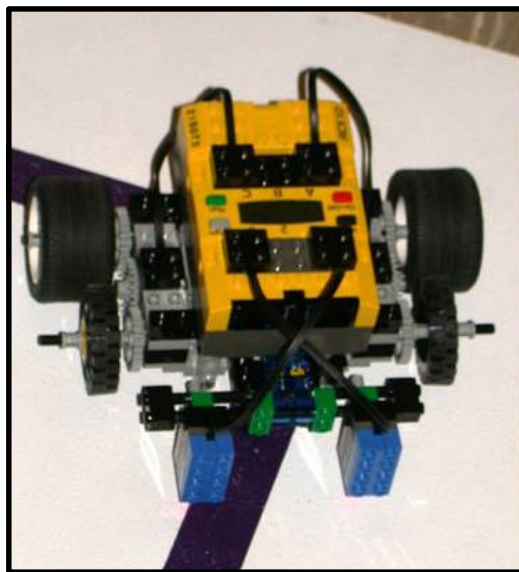

Figure 3. Simple line-following robot with light sensors.

To provide an entry level that is attractive to both upper elementary and middle school teachers, the morning session initially focuses on the Lego Mindstorms™ Robotics Invention System (RIS 2.0). RIS 2.0 is a very powerful educational tool disguised as a toy. The heart of the system is the RCX Programmable Brick (RCX 1.0), a microprocessor-based embedded controller housed in an

over-sized Lego™ brick (see Figure 3). Built into the battery-powered RCX are three A/D inputs, three 9-volt outputs and an infrared (IR) link for communication with a host computer or other controllers. RIS 2.0 also includes 2 motors, 2 touch sensors, one light sensor, over 800 Lego™ pieces (plates, blocks, gears, axles, etc.) and software designed to allow upper elementary and middle school students to program robots that they have built. Beyond the basics, the project also covers advanced topics including object-oriented design and programming of the RCX Brick using Java and other high-level programming languages, real-time network protocols (including the Lego Network Protocol), developing simple sensors and actuators, using robots in embedded system design, and verifying the correctness of embedded system designs.

Designing and programming the robots naturally motivate both teachers and students to acquire a much deeper understanding of the underlying mathematics (including logic, geometry, algebra, and discrete mathematics), science (including measurement, the scientific process, and physics), and engineering. In addition to working on simple embedded control systems (using RIS 2.0) that they take back to their own schools, teachers also work with graduate research students and faculty members on more complex real-time embedded systems. In this way, they gain a deeper understanding of embedded system design and learn how to apply basic principles to more complex designs. For example, a typical complex application includes variable rate technology for use in an agricultural applications (see Figure 2).



Figure 4. RET-Site teacher programming a robot with a custom distance sensor.

Most team sports in schools require athletic ability and many capable students are not good athletes. The Kansas Robotics League was conceived of to bring the benefits of competition to students in an academic, not athletic, environment. It was also designed to foster the attitude in

students that *engineering is a viable and rewarding career option*, thus encouraging them to enroll in the math and science classes needed for admission to college. Teachers spend a total of four weeks on campus, followed by active participation in the Kansas Robotics League during the rest of the year, and beyond.

Currently, admission to the Kansas Robotics League is based upon Rogers' Diffusion of Innovations Model. In the first year (2001-2002), four schools participated. In the second year (2002-2003), 22 schools participated with over 75 students attending the league meet. The meet was held during the Kansas State University open house and the students, mostly low-SES urban and rural, had ample time to visit the campus. The teachers' reaction was very positive. Some are taking the initiative to host their own meets. Student reactions have also been encouraging. One student, a minority student from a Title I school, wrote a mini-grant to help him explore career opportunities in robotics. Another student, a rural, at-risk female, made a presentation on robots to her school's accreditation committee during the committee's visit.

The goals of the Robotics League are two-fold: increase the knowledge and improve the attitudes of teachers on the subject of engineering and increase the knowledge and improve the attitudes of their students on the subject of engineering. In order to make such an assessment, a quasi-experimental design has been developed. A similar experimental design was developed for this project. At this point, the project analysis is still in progress and will be reported in a future publication. In the next subsection, we focus on activities carried out during this past summer.

3.2 Teacher Activities

The project curriculum can be roughly divided into hardware and software components. The morning session is more focussed on software components, whereas the afternoon session is more focussed on hardware components.

Software components begin with an introduction to graphical programming languages (RIS 2.0 and RoboLab 2.5 (based on National Instrument's LabViewTM)) to design control software for the robots and use the robots for data acquisition. This leads to a natural transition to object-oriented programming languages (Java) and real-time operating systems (LeJOS, BrickOS). After covering the basics of object-oriented programming, teachers learn how to model various different robotic behaviors and compete in different robotic challenges. Then, they interface the robots with both new and existing sensors and learn how to calibrate these new sensors. For example, a robot equipped with a custom-built distance sensor can be programmed to implement a wall following behavior as shown in Figure 4. Finally, designs are verified using verification tools. Teachers are involved in both software design (developing new code to implement different robotic behaviors, etc.) and hardware design (developing new sensors and actuators).

The hardware component begins with a set of basic electronics laboratories covering basic lab safety and equipment (multimeters, oscilloscopes, function generators, soldering irons, etc.), electronic components (resistors, capacitors, transistors, regulators, etc.), and sensor and actuator development (thermistors, distance sensors, compass sensors, etc.) (see Figure 5).



Figure 5. Basic electronics laboratory.

Teachers are very enthused about the hands-on nature of these laboratories, and they provide a good springboard to more advanced sensor research on bioengineering applications – for this year, the focus was on variable-rate technology and biosensors. Below is a list of the ten labs completed during the first two weeks of the summer program:

Basic Electronics Labs:

1. Introduction to safety features of the real-time instrumentation laboratory
2. Digital multimeter usage and functions
 - a. Measuring voltage, current, and resistance
 - b. Build and prototype a simple circuit
3. Resistors and thermistors
 - a. Calibration
 - b. Construct temperature sensor for Lego Mindstorms RCX 1.0
 - c. Test with a simple program to display raw and calibrated values
4. Series and parallel circuits
 - a. Ohm's Law and application
 - b. Predict and measure resistance, voltage drops, etc.

5. Diodes and Capacitors
 - a. Study the rectification function of diodes
 - b. Study the filtering function of capacitors

6. Digital Oscilloscope
 - a. Safety features and functions
 - b. Types of probes
 - c. Use with function generator to test simple circuits

7. Zener Diodes
 - a. Study the clamping function of diodes
 - b. Study the voltage regulation function of zener diodes

8. Distance Sensor
 - a. Prototype a simple distance sensor circuit from schematic
 - b. Construct the sensor for use with Lego Mindstorms RCX 1.0
 - c. Test by writing a wall follower program, etc.

9. Compass Sensor
 - a. Prototype a more complex compass sensor from schematic
 - b. Construct the sensor for use with Lego Mindstorms RCX 1.0
 - c. Test by writing a square drawing program, etc.

10. Seven-segment LED Display and Decoder Driver
 - a. Binary number system
 - b. Logic gates

After covering basic electronics, teachers focus on more advanced sensors used in various bioengineering applications such as variable-rate technology and grain handling; e.g., light sensors (both visible and infrared), humidity sensors, temperature sensors, touch sensors, etc. Teachers work together with graduate students and faculty in on-going research projects, both in the laboratory and in the field. Since Kansas State University is a land-grant institution, there is a great deal of research activity on embedded designs in engineering and agriculture. Teachers practice the software engineering skills learned during the morning sessions and the electronic design skills learned during the afternoon sessions to become familiar with contemporary research activities – both experimental and analytical designs.

For example, a weed detection system is capable of detecting weed infestations at different density levels (see Figure 1). Based on the density of infestation, chemicals are applied at different rates, in real time. Such agricultural applications are referred to as variable-rate technology (VRT). Infrared sensors are used to collect information (Figure 2). Then, distributed controllers evaluate the input and generate variable-rate application recommendations in real-time. All sensors, controllers, and actuators are networked together using a real-time controller area network. Data is collected from the field and combined with sensor data using a Geographic Information System (GIS). Developers focus on techniques that allow an embedded system to

satisfy certain performance requirements. Embedded system developers must be able to evaluate various design choices and make decisions accordingly. Some of the aims of the project include: understanding techniques to satisfy constraints related to real-time, fault-tolerance, correctness, etc.; using a well-defined engineering approach (starting with a high-level design specification and leading to a structured component-based implementation); and bridging the gap between theory and practice so that participants can apply theoretical knowledge to practice.

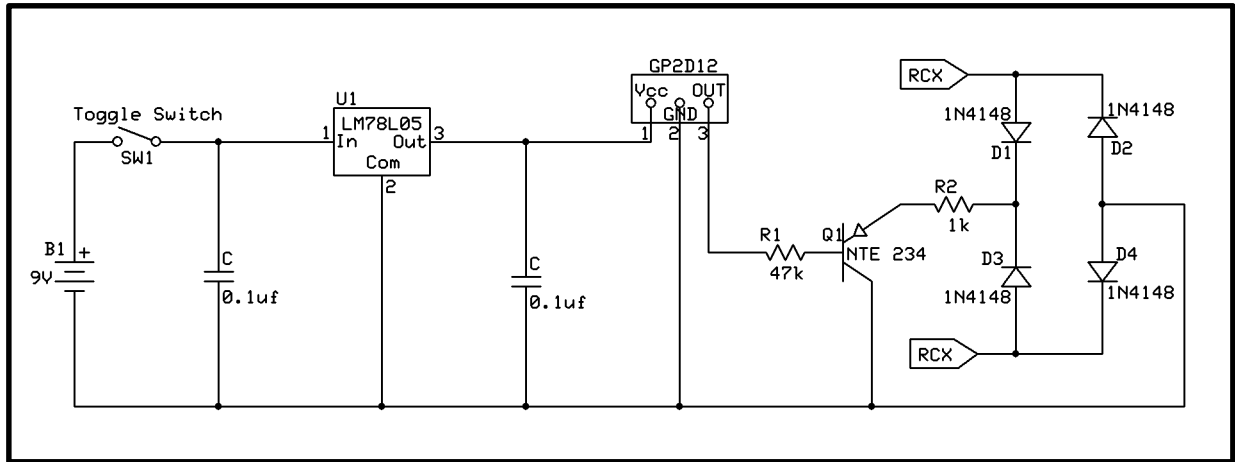

Figure 6. Distance sensor circuit.

One of the sensors developed in the labs during the summer session was a distance sensor (see Figures 4). To reduce environmental impacts, we used 1.2v NiMH batteries to power the RCX. As a result, circuits that use the RCX brick batteries to power the sensor don't provide enough voltage to power the sensor effectively. This same problem exists for many existing circuits in press. To provide a more generic solution, we designed a new circuit to power the sensors through an external power supply. This circuit is shown above in Figure 6.

Once developed, the sensor must be calibrated. Teachers develop software to take raw readings (see Figure 7) from the sensor. With some elementary mathematics, the raw readings can be translated into distances. Of course such simple translations can be used in an elementary classroom to motivate the need to study ratios and fractions. A compass sensor was also designed (see Figure 8). Input from the sensor includes raw values that can be translated into sine and cosine values. Then, some simple trigonometry is required to compute an angle from these calibrated raw readings. Most simple sensors can be used to motivate many different math and science concepts at the elementary and middle school level.

During the second half of the summer session, teachers combine what they have learned to develop an innovative individual research project. Sensors, actuators, robots, and software are all developed to complete their individual research projects. Initial research results are completed and reported during a wrap-up session at the end of the summer. Final presentations of research results will be presented at professional meetings and during a poster session on campus at Kansas State University during a special poster session in April 2004.

```

// DistanceTest – used to test and calibrate a distance sensor

import josx.platform.rcx.*;

public class DistanceTest implements SensorConstants {

    private Sensor sharpSensor;

    public DistanceTest (Sensor sharpPort) {
        sharpSensor = sharpPort;
        sharpSensor.setTypeAndMode (SENSOR_TYPE_RAW,
        SENSOR_MODE_RAW);
        sharpSensor.passivate();
        try{
            Thread.sleep(1000);
        } catch(Exception e){}
    }

    public synchronized int getRaw() {
        int raw = Sensor.S1.readValue();
        return raw;
    }

    public static void main(String[] args) {
        DistanceTest dt = new DistanceTest(Sensor.S1);
        while (true) {
            LCD.showNumber(dt.getRaw());
            Sound.bEEP();
        }
    }
}

```

Figure 7. Distance sensor test code.

Teachers also develop curricular modules to be used directly within their own classrooms. Support is provided by faculty members and graduate students during the academic year through the Kansas Robotics League. This provides us with an avenue for on-going contact. It also provides many upper elementary and middle school students with an opportunity to compete at the state level in robotics and embedded system design contests during Open House at Kansas State University. All of these opportunities naturally motivate both teachers and students to acquire a much deeper understanding of the underlying mathematics and science used in embedded system design.

Bibliography

- [1] M.L. Neilsen, D.H. Lenhert, M. Mizuno, G. Singh, N. Zhang, and A.B. Gross, "An interdisciplinary curriculum on real-time embedded systems", In Proceedings of the 2002 American Society for Engineering Education (ASEE) Annual Conference and Exposition, Montreal, Quebec, 2002.
- [2] M.L. Neilsen, "A flexible real-time transport protocol for controller area networks", In Proceedings of the International Conference on Parallel and Distributed Processing Techniques and Applications (PDPTA'01), pp. 250-256, June 25-28, 2001.
- [3] J. Wei, N. Zhang, N. Wang, D. Lenhert, M. Neilsen, M. Mizuno, and G. Singh, "Design of an embedded weed-control system using Controller Area Network (CAN)", ASAE Paper No. 01-3033, American Society of Agricultural Engineers, ASAE 2001 Annual International Meeting, July 29 – August 1, 2001.
- [4] W. Wolf, "Rethinking embedded microprocessor education", In Proceedings of the 2001 American Society for Engineering Education Annual Conference and Exposition, Albuquerque, NM, 2001.
- [5] W. Wolf and J. Madsen, "Embedded systems education for the future", In Proceedings of the IEEE, 88(1), pp. 23-30, January 2000.
- [6] N. Zhang, "DSP signal processing for a particle velocity sensor", In Proceedings of the American Society of Agricultural Engineering, Number 98-3036, 1998.
- [7] N. Zhang, R. Taylor, S. Runquist, E. Runquist, M. Schrock, and S. Staggenborg, "A field-level geographic information system (FIS) and precision agriculture", In Proceedings of the International Conference on Agricultural Engineering, Dec. 1998.
- [8] N. Zhang and N. Wang, "Effectiveness of a polarized laser light in soil moisture-content measurement", In Proceedings of the American Society of Agricultural Engineering, Number 99-3113, 1999.

Biographical Information

MITCHELL L. NEILSEN is an Associate Professor in the Department of Computing and Information Sciences at Kansas State University. His research interests include real-time embedded systems, distributed systems, and distributed scientific computing.

DONALD H. LENHERT is the Paslay Professor in the Department of Electrical and Computer Engineering at Kansas State University. His research interests include embedded systems and digital testing.

MASAAKI MIZUNO is a Professor in the Department of Computing and Information Sciences at Kansas State University. His research interests include operating systems and distributed systems.

GURDIP SINGH is a Professor in the Department of Computing and Information Sciences at Kansas State University. His research interests include network protocols, distributed systems, and verification.

JOHN R. STAVER is a Professor of Education (Science) in the College of Education. His research interests include constructivist epistemology and its applications to teaching and learning science, and public understanding of science as it relates to the controversy over evolution and the nature of science.

NAIQIAN ZHANG is a Professor in the Department of Biological and Agricultural Engineering. His research interests include sensors and controls for biological and agricultural systems.

KEVIN M. KRAMER is a Doctoral Candidate in Curriculum and Instruction at Kansas State University, and research assistant in the College of Education's Department of Foundations and Adult Education. Research Interests included gender issues in computer technology and training.

WILLIAM J. RUST is a Graduate Student in the College of Education at Kansas State University. His research interests include the use of technology in the classroom and the history of school reform.

QUENTIN STOLL is a Graduate Student in the Department of Biological and Agricultural Engineering. He is conducting research on variable-rate technology.

MD SHARIF UDDIN is a Graduate Student in the Department of Biological and Agricultural Engineering. He is conducting research on wireless sensors for use in the grain industry.